

N=Number of Positions

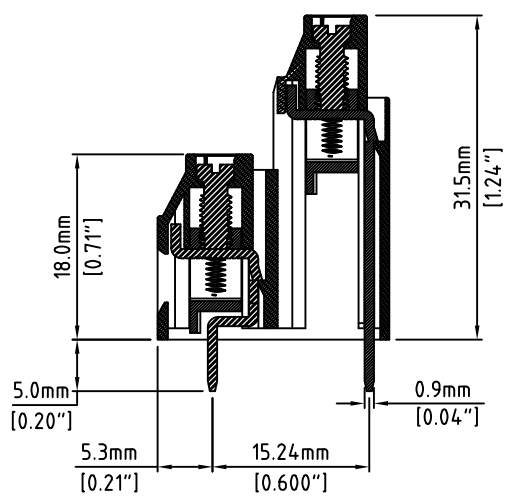
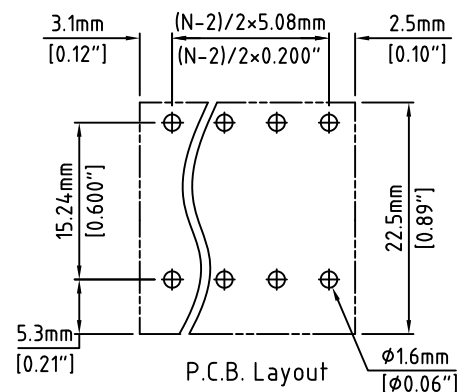

Material:	
Contact Block:	Brass, Ni Plated
Contact Solder Pin:	Brass, Tin Plated
Screw:	M3, Steel, Zinc Plated, "-" slotted
Insulating Body:	Polyamide, UL94V-0, Green
Electrical	
Voltage Rating:	300 VAC
Current rating:	20 AMPS
Withstand Voltage:	1500 VAC, Test time 60 sec
Wire Range:	12-22 AWG
Mechanical	
Torque:	4.3 lbs-in. Max
Operating Temperature:	-40°C to +105°C -40°F to +221°F
Soldering Temperature:	260°C, 500°F for 5 seconds
Safety Approval:	

Part Number Configuration.

EB1268-XX-500

Total Number of Pins: XX
Color Option: 5-Green

(Other Color Options Available)
(Please consult Factory)

Max Number of Positions = 2x24

UNLESS OTHERWISE SPECIFIED BREAK ALL SHARP EDGES AND DEBURR ALL HOLES
 TITLE: 5.08mm SPACING, CAGE CLAMP BLOCK DUAL LEVEL, PARALLEL

LIMITS: UNLESS OTHERWISE SPECIFIED HUND.±.02 FRACT.±1/64 THOU.±.005 ANGLE±1°	SCALE	THIS IS A CONFIDENTIAL DRAWING AND MUSTBE TREATED AS SUCH. NO DISTRIBUTION IS ALLOWED WITHOUT WRITTEN APPROVAL BY EB1 ELECTRO INC.	Electro Inc. PLAINVIEW, NY 11803
---	-------	--	-------------------------------------

IMPORTANT DISCLAIMER: All information provided on this print is for reference. Always perform your own tests and acquire samples and further information to determine product suitability. While we make effort to provide accurate information, we cannot be responsible for errors either of omission or typographical. EB1 Electro, Inc. assumes no responsibility for the use or suitability of any product. All products and specifications are subject to change without prior written notice.

METRIC LIMITS ONE PLACE ±0.3 TWO PLACES ±0.10 ANGLE ±1°	DRAWN JM CHECKED APPROVED	DATE 02/14/08 DATE DATE	SIZE A	DRAWING NUMBER: EB1268-XX-500	REV.
--	---------------------------------	-------------------------------	--------	----------------------------------	------